

PRODUCT INFO SHEET

Nanmac Corporation

Quality • Performance • Solutions

Thermowell with Lagging Extension A22A Series

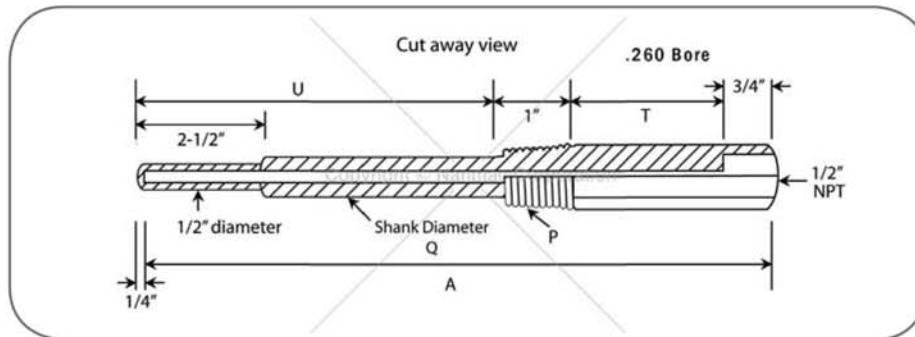

NOTES:

- When ordering, order by Part No. as indicated.
- Stainless steel or brass compression fittings are available for mounting probes into these thermowells.

Typical Pressure - Temperature Rating - PSI

Material	Temperature - °F						
	70°	200°	400°	600°	800°	1000°	1200°
Brass	5000	4200	1000				
Carbon Steel	5200	5000	4800	4600	3500	1500	
SS 304	7000	6200	5600	5400	5200	4500	1650
SS 316	7000	7000	6400	6200	6100	5100	2500
Monel	6500	6000	5400	5300	5200	1500	

Specifications

Lagging Ext. T	Ext. Thread P	Stem Length A	Insertion Length U	Shank Diameter Q	Bore Diameter = 0.260"			
					Material SS 304	Material SS 316	Material Carbon Steel	Material Brass
					Part No.	Part No.	Part No.	Part No.
2 3 3 3 3 3	1/2" NPT	6	2-1/2	5/8"	A22A-1	A22A-19	A22A-37	A22A-55
		9	4-1/2		A22A-2	A22A-20	A22A-38	A22A-56
		12	7-1/2		A22A-3	A22A-21	A22A-39	A22A-57
		15	10-1/2		A22A-4	A22A-22	A22A-40	A22A-58
		18	13-1/2		A22A-5	A22A-23	A22A-41	A22A-59
		24	19-1/2		A22A-6	A22A-24	A22A-42	A22A-60
2 3 3 3 3 3	3/4" NPT	6	2-1/2	3/4"	A22A-7	A22A-25	A22A-43	A22A-61
		9	4-1/2		A22A-8	A22A-26	A22A-44	A22A-62
		12	7-1/2		A22A-9	A22A-27	A22A-45	A22A-63
		15	10-1/2		A22A-10	A22A-28	A22A-46	A22A-64
		18	13-1/2		A22A-11	A22A-29	A22A-47	A22A-65
		24	19-1/2		A22A-12	A22A-30	A22A-48	A22A-66
2 3 3 3 3 3	1" NPT	6	2-1/2	7/8"	A22A-13	A22A-31	A22A-49	A22A-67
		9	4-1/2		A22A-14	A22A-32	A22A-50	A22A-68
		12	7-1/2		A22A-15	A22A-33	A22A-51	A22A-69
		15	10-1/2		A22A-16	A22A-34	A22A-52	A22A-70
		18	13-1/2		A22A-17	A22A-35	A22A-53	A22A-71
		24	19-1/2		A22A-18	A22A-36	A22A-54	A22A-72

PO Box 6640
1657 Washington St., Bldg. 3
Holliston MA 01746
www.Nanmac.com
engineering@nanmac.com

Foremost in Temperature Measurement™
NANMAC

US & Canada: 1.800.786.4669
International: 1.508.872.4811
Fax: 1.508.879.5450
info@nanmac.com