

Heavy Duty Tapered Thermowells with Lagging Extension for 1/4" & 3/8" Diameter Elements A26A Series

Most thermowell assemblies use female NPT threads and accept male NPT pipefittings. Due to normal tolerance and torque variations during assembly variations as much as 5/8" in element lengths can be encountered. When ordering replacement parts care should be taken to allow for normal variations in length. When ordering complete assemblies, Nanmac will make the necessary adjustments to compensate for these variations in lengths.

If all other variables are held constant, accuracy depends upon the insertion length "U" the distance between the tip of the wall and the underside of the threads, or attachment means. When space and pressure-temperature ratings permit, accuracy can be improved by increasing the insertion length. The error in temperature measurement of short insertion length thermowells is created by the thermal conduction from the tip of the wall and thence to the outside atmosphere. This is commonly referred to as the error caused by "The Stem Effect."

In addition to conventional thermocouple sensors installed in the metal thermowell, spring-loaded thermocouples can also be installed in the metal thermowell. These units keep the thermal junction in good thermal contact with the thermowell at all times; thus, improving the response times of the complete assembly. Contact us or a Nanmac engineer for more details.

NOTES:

- Order by part number as indicated in the table on page two.
- Stainless steel or brass compression fittings are available for mounting probes into these thermowells.
- Brass cap and chain are available for keeping well bore clean when not in use.
- If cap and chain is desired add suffix "BRcap" or "SScap" to part number.

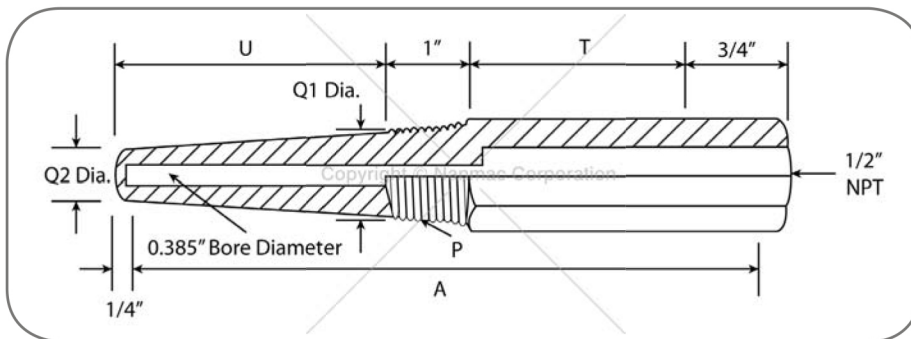

1/4" Diameter Probe Specifications							
Material	Temperature °F						
	70°F	200°F	400°F	600°F	800°F	1,000°F	1,200°F
Brass	5,300	4,750	1,100	-	-	-	-
Carbon Steel	5,950	5,750	5,450	5,250	4,000	1,750	-
SS 304	7,800	7,050	6,400	6,150	6,000	5,190	1,875
SS 316	7,800	7,800	7,250	7,100	6,950	5,800	2,720
Monel	7,450	6,850	6,150	6,100	5,940	1,750	-

3/8" Diameter Probe Specifications							
Material	Temperature °F						
	70°F	200°F	400°F	600°F	800°F	1,000°F	1,200°F
Brass	5,000	4,200	1,000	-	-	-	-
Carbon Steel	5,200	5,000	5,800	4,600	3,500	1,500	-
SS 304	7,000	6,200	5,600	5,400	5,200	4,500	1,675
SS 316	7,000	7,000	6,400	6,200	6,100	5,100	2,500
Monel	6,500	6,000	5,400	5,360	5,200	1,500	-

Stainless Steel Unit Specifications							
Lagging Extension (T)	Exterior Thread (P)	Element Length (A)	Insert Length (U)	Bore Diameter (B) 0.260" Shank Diameter Q1-7/8" Q2-5/8"		Bore Diameter (B) 0.385" Shank Diameter Q1-1-1/16" Q2-49/64"	
				SS 304	SS 316	SS 304	SS 316
				Part No.	Part No.	Part No.	Part No.
2	3/4" NPT	6	2-1/2	A26A-1	A26A-13	N/A	N/A
3		9	4-1/2	A26A-2	A26A-14		
3		12	7-1/2	A26A-3	A26A-15		
3		15	10-1/2	A26A-4	A26A-16		
3		18	13-1/2	A26A-5	A26A-17		
3		24	19-1/2	A26A-6	A26A-18		
2	1" NPT	6	2-1/2	A26A-7	A26A-19	A26A-25	A26A-31
3		9	4-1/2	A26A-8	A26A-20	A26A-26	A26A-32
3		12	7-1/2	A26A-9	A26A-21	A26A-27	A26A-33
3		15	10-1/2	A26A-10	A26A-22	A26A-28	A26A-34
3		18	13-1/2	A26A-11	A26A-23	A26A-29	A26A-35
3		24	19-1/2	A26A-12	A26A-24	A26A-30	A26A-36

Carbon Steel & Brass Unit Specifications							
Lagging Extension (T)	Exterior Thread (P)	Element Length (A)	Insert Length (U)	Bore Diameter (B) 0.260" Shank Diameter Q1-7/8" Q2-5/8"		Bore Diameter (B) 0.385" Shank Diameter Q1-1-1/16" Q2-49/64"	
				Brass	Carbon Steel	Brass	Carbon Steel
				Part No.	Part No.	Part No.	Part No.
2	3/4" NPT	6	2-1/2	A26A-37	A26A-49	N/A	N/A
3		9	4-1/2	A26A-38	A26A-50		
3		12	7-1/2	A26A-39	A26A-51		
3		15	10-1/2	A26A-40	A26A-52		
3		18	13-1/2	A26A-41	A26A-53		
3		24	19-1/2	A26A-42	A26A-54		
2	1" NPT	6	2-1/2	A26A-43	A26A-55	A26A-61	A26A-67
3		9	4-1/2	A26A-44	A26A-56	A26A-62	A26A-68
3		12	7-1/2	A26A-45	A26A-57	A26A-63	A26A-69
3		15	10-1/2	A26A-46	A26A-58	A26A-64	A26A-70
3		18	13-1/2	A26A-47	A26A-59	A26A-65	A26A-71
3		24	19-1/2	A26A-48	A26A-60	A26A-66	A26A-72

(Page 2 of 2)