

PRODUCT INFO SHEET

Nanmac Corporation

Quality • Performance • Solutions

Conduit Heads Explosion Proof (EP) & Atex Approved (ATEX) F7-8 & F7-9 Series

Explosion Proof (EP) & Atex Approved (ATEX) heads are available in cast aluminum or stainless steel, screw cover units. These units are rated for use in hazardous environments where extreme caution must be observed. Internal threaded holes accommodate four wire terminal blocks. Various terminal blocks are available.

Explosion Proof Zone Approval:

- Class I, Div 1, Group B, C & D
- Class II, Div 1, Groups E, F & G
- NEMA 4x, Type 4
- **ATEX:** Ex d 11C T6 IP68
- **ATEX:** Ex tD A21 T100°C IP68

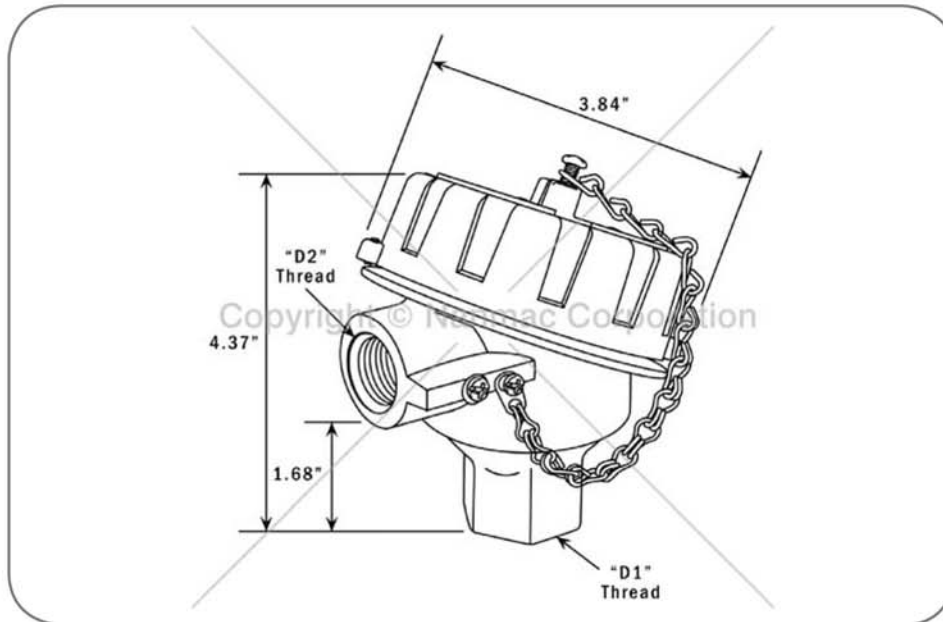

Specifications

Part No.	Material	Epoxy Color	Order Certification	Thread Sizes (PE x CE)
F7-8-1212-AL F7-8-1234-AL F7-8-3434-AL	Aluminum	Blue	ATEX	1/2" x 1/2" NPT 1/2" x 3/4" NPT 3/4" x 3/4" NPT
F7-8-1212-SS F7-8-1234-SS F7-8-3434-SS	SS316	-	ATEX	1/2" x 1/2" NPT 1/2" x 3/4" NPT 3/4" x 3/4" NPT
F7-9-1212-AL F7-9-1234-AL F7-9-3434-AL	Aluminum	Silver	FM & CSA	1/2" x 1/2" NPT 1/2" x 3/4" NPT 3/4" x 3/4" NPT
F7-9-1212-SS F7-9-1234-SS F7-9-3434-SS	SS316	-	FM & CSA	1/2" x 1/2" NPT 1/2" x 3/4" NPT 3/4" x 3/4" NPT

PO Box 6640
1657 Washington St., Bldg. 3
Holliston MA 01746
www.Nanmac.com
engineering@nanmac.com

Foremost in Temperature Measurement™
NANMAC

US & Canada: 1.800.786.4669
International: 1.508.872.4811
Fax: 1.508.879.5450
info@nanmac.com