

PRODUCT INFO SHEET

Nanmac Corporation

Quality • Performance • Solutions

Canister Heads F7-8380 Series

The Nanmac F7-8380 Series Canister Heads are small nickel-plated steel enclosures designed for applications where space is limited. These canister heads can be provided with 2, 3, or 4 terminals for both thermocouples and RTDs, up to #20 gauge (0.032 inch diameter) wire.

These units come equipped with an O-ring moisture seal and a neoprene cap grommet to help prevent water ingress. The F7-8380 Series comes with either, 1/4 or 1/8 inch NPT opening.

NOTES:

- O-Ring Seal
- 2, 3, or 4 Terminal
- Neoprene cap grommet comes standard
- Up to #20 gauge (0.032 inch) wire

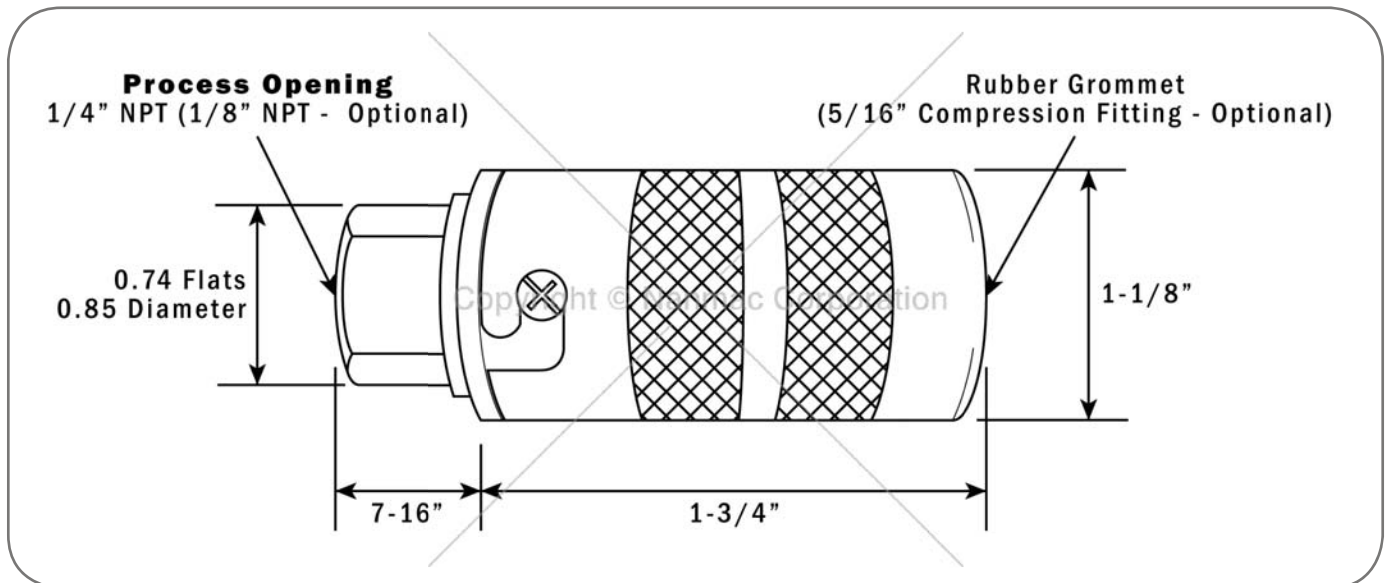

Specifications

Part No.	Number of Terminals	Material	Description	Process Opening
F7-8380-2-18 F7-8380-2-14	2	Nickel-Plated Steel	Canister Head	1/8" NPT 1/4" NPT
F7-8380-3-18 F7-8380-3-14	3	Nickel-Plated Steel	Canister Head	1/8" NPT 1/4" NPT
F7-8380-4-18 F7-8380-4-14	4	Nickel-Plated Steel	Canister Head	1/8" NPT 1/4" NPT

11 Mayhew Street
Framingham, MA 01702
www.Nanmac.com
engineering@nanmac.com

Foremost in Temperature Measurement™
NANMAC

US & Canada: 1.800.786.4669
International: 1.508.872.4811
Fax: 1.508.879.5450
info@nanmac.com